



COMBINATION FIRE/SMOKE DAMPERS (STATIC AND DYNAMIC)

UL File No.
R25410

Installation Instructions

General Notes:

When UL is referred to in this document, it represents UL/ULC. This installation instruction applies to Fire/Smoke Dampers (3-V, Airfoil, Parallel, Opposed, Single, and Multi-blade types) mounted in the plane of an UL approved fire partition. Combination Fire/Smoke dampers are approved for use in Static or Dynamic Systems. The dampers are designed for operation in the vertical or horizontal position with blades running horizontal. Horizontal installations similar to vertical shown. The dampers to be installed square and free from twisting or racking. The dampers shall not be



compressed or stretched into the opening. Transportation and installation of the dampers shall be handled with the sleeve or frame. Do not lift the damper with the blades or actuator. Special care shall be given to the damper before installation and after to insure it is protected against dirt weather, mortar and drywall dust, wall texture and paint. Any of these conditions could cause the damper not to operate correctly and void the warranty. Suitable access to inside duct is to be provided for inspection and replacement of parts such as heat response devices and actuators per NFPA 90A and local authority having jurisdiction. The need to seal the damper in the penetration is not required by Underwriters Laboratories. United EnerTech dampers have been tested and approved to be mounted without the use of sealants around the perimeter space between the damper and the penetration. As with all joints, contractor must seal duct collar connections in the field after installation. UE Model numbers which are UL approved to utilize this installation are F/S-3V-I, (-II), F/S-3V-3-I, (-II), F/S-AF-I, (-II), F/S-AF-3-I, (-II), FD-110-3V, FD-160-AF, FDD-110-3V, FDD-160-AF, FD-A-3V.

1. Opening Preparation / Clearances:

The fire barrier opening shall be larger than the damper to allow for thermal expansion and ease of installation. When steel stud/gypsum or wood stud/gypsum partitions are being used then refer to Fig. 1-3 for additional information and details.

A. Dampers Assemblies Using 2 Angles Methods (see note 4a) shall be a minimum of 1/8" (3mm) per linear foot (305mm) of height and width of sleeved assembly up to a maximum of 1-1/2" (38mm) and a minimum of 1/4" (6mm). The maximum single section multi-blade damper is 36" x 48" (914mm x 1219mm) in vertical or horizontal mountings. This method is acceptable for 1-1/2 and 3 hour fire dampers. See Underwriter's Laboratories Listings for maximum multiple assembly sizes.

B. Dampers Assemblies Using 1 Angle Methods (see note 4b) shall be minimum of 1/8" (3mm) per linear foot (305mm) of height and width of sleeved assembly up to a maximum of 1-1/2" (38mm) and a minimum of 1/4" (6mm). The maximum single section is the same as in A above. The maximum multi-section is 108" w or 108" h up to 36 square feet. This method is acceptable for 1-1/2 hour fire dampers mounted in a masonry/concrete or steel stud/gypsum partitions only.

C. Dampers Assemblies Using No Angles Methods (see note 4c) shall be a minimum of 1/4" (6mm) and a maximum of 1/2" (13mm). The maximum single section is the same as in A above. The maximum multi-section is 42" w x 48" h. This method is acceptable for 1-1/2 hour fire dampers mounted in a masonry/concrete or steel stud/gypsum partitions only.

Fig. 1: Metal Stud/Gypsum Design

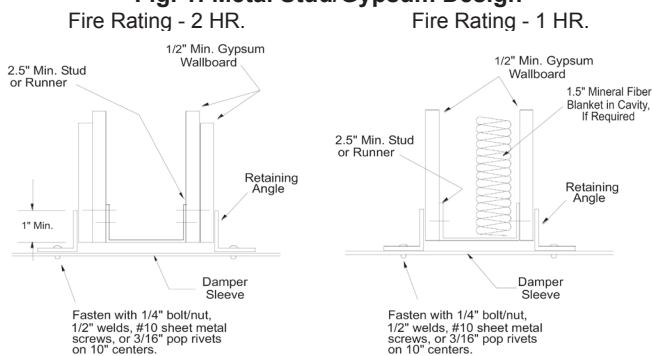
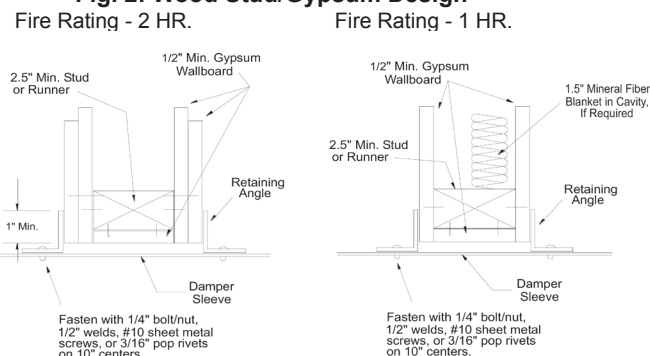

Fig. 2: Wood Stud/Gypsum Design



2. Damper Sleeves and Breakaway Connections:

Sleeves shall be of the SAME GAGE or heavier as the duct to which it is attached, if one of the breakaway connection is used as defined in the SMACNA Fire, Smoke and Radiation damper Guide for HVAC Systems (Fig. 4-6) and in NFPA 90A. Gauges shall conform to SMACNA or ASRAE duct standards. Sleeves shall not extend beyond the fire barrier more than 6" (152mm) unless an actuator or factory installed access door is supplied, then the sleeve may extend up to 16" (406mm). Sleeve shall terminate at both sides of wall within dimensions shown. If a rigid connection is used, then the sleeve shall be minimum of 16 gage for dampers up to 36" (914mm) wide by 24" (610mm) high and 14 gage for dampers exceeding 36" (914mm) wide by 24" (610mm) high.

Round and oval breakaway connections must use either a 4" (102mm) wide draw band or #10 (M5) sheet metal screws spaced equally around the circumference of the duct as follows: 3 screws for duct sizes 22" (559mm) and smaller; 5 screws for duct sized greater than 22" (559mm) and up to and including 36" (914mm); 8 screws for duct sizes greater than 36" (914mm). Refer to SMACNA Fire, Smoke and Radiation Damper Guide for HVAC Systems for information on Ductmate, Nexus, ward, TDC and TDF systems and any additional information (Fig. 5-6). A sleeve may not be required if the damper frame is of sufficient size and shape so the mounting angles can be directly fastened to it.

3. Multi-Section and "Damper to Sleeve" Connections:

Damper shall be secured to the sleeve and to each other (when joined to make multiple damper assemblies) with #10 sheet metal screws, 1/4" (6mm) nut and bolts, 1/4" (6mm) tack welds, 3/16" (5mm) steel rivets, or clinching (toggle) on 6" (152mm) centers. Both sides of the frame are to be secured to the sleeve. When field assembling multi-sections, a continuous 1/8" (3mm) bead of Dow Corning 999, Dow Corning Silastic 732, Nuflex 302, or GE RTV 108 Sealant shall be applied to the frame joints and where the frame connects to the sleeve. Sealant is required only on one side of the damper. Press the surface of the sealant in place to dispel any air.

COMBINATION FIRE/SMOKE DAMPERS

(STATIC AND DYNAMIC)

Installation Instructions (continued)

Fig. 3: Metal or Wood Stud Wall

Note: Gypsum panels screwed to all studs and runner flanges, 12" oc maximum surrounding opening. All fasteners are to be UL approved per UL design.

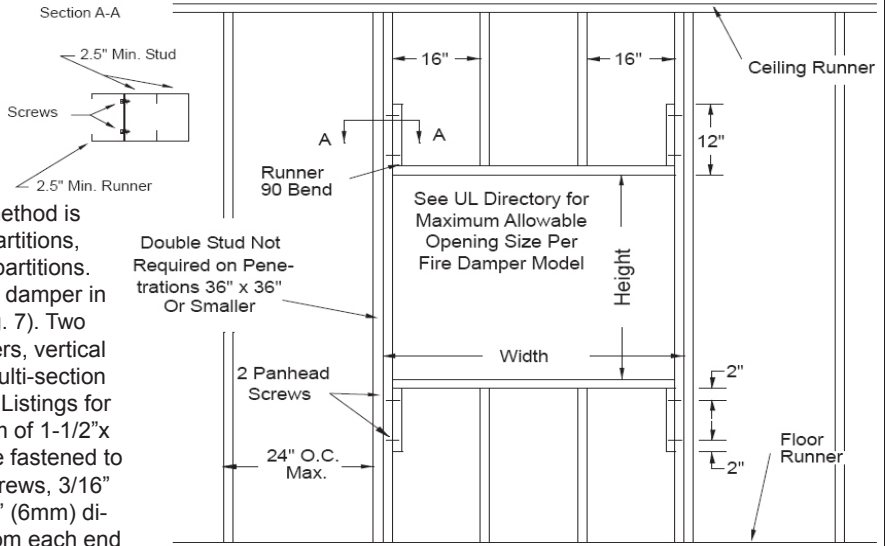

4. Methods of Securing Damper in Opening:

a. Two Angle (Two Sided) Method:

This method is the oldest and commonly used. This method is approved for use in UL approved concrete/masonry partitions, steel stud/gypsum partitions, and wood stud/gypsum partitions. In this method 2 sets of angles are used to secure the damper in the opening, one on each side of the partition (See Fig. 7). Two Angle Method is approved for 1-1/2" and 3 hour dampers, vertical or horizontal orientation, and any maximum size multi-section UL approved damper (see Underwriter's Laboratories Listings for maximum assembly sizes). Angles shall be a minimum of 1-1/2"x 1-1/2" on (37mmx37mm) x 16 gauge. Angles are to be fastened to the sleeve on 6" centers with #10 (M5) sheet metal screws, 3/16" (5mm) steel pop rivets, 1/2" (13mm) tack welds, or 1/4" (6mm) diameter nut and bolts with not more than 2" (51mm) from each end

with a minimum of two connections per side/leg. The angles are to overlap the partition a minimum of 1" (25mm). These angles may be of a unit type construction and may or may not be fastened to each other at the corners. When the duct work terminates at the damper or installation prohibits angles from turning out/away from the wall, the retaining angle shall be reversed (leg turned into the opening) providing the size of the opening is increased by an amount equal to twice the combined thickness of the angle and the height of the screw or bolt head to maintain expansion clearances. See note 1A for information on clearances. See Fig. 7 for detailed drawings of installations.

b. One Angle (Single Sided) Method: In this method 1 set of angles are used to secure the damper in the opening. This method is approved for use in UL approved concrete/masonry partitions and steel stud/gypsum walls. Only one side of the fire partition will have the angles installed (see Fig. 8). One Angle Method is approved for 1-1/2 hour dampers only, vertical and horizontal (angles on top side only) orientations, and the maximum size shall be 108" wide or 108" high up to 36 square feet and up to the maximum multi-section UL approved damper size (see Underwriter's Laboratories Listings for maximum assembly sizes). Angle shall be a minimum of 1-1/2" x 1-1/2" (37mmx37mm) by 16 gauge. Angles are to be fastened to the sleeve on 6" centers with #10 (M5) sheet metal screws, 3/16" (5mm) steel pop rivets, 1/2" (13mm) tack welds, or 1/4" (6mm) diameter nut and bolts with not more than 2" (51mm) from each end with a minimum of two connections on each side/leg top and bottom. The angles are also to be fastened to the fire partition with: in concrete/masonry partitions with #10 (M5) self-tapping concrete anchors or concrete screws on 6" (152mm) centers and must engage the fire partition a minimum of 1-1/2" (38mm); in steel stud/gypsum partitions secure the angles to the partition with #10 (M5) screws long enough to penetrate the J-Runners and E-Stud by a minimum of 3/8" (10mm). Use a minimum of two fasteners per side. The angles are to overlap the partition a minimum of 1" (25mm). These angles may be of a unit type construction and may or may not be fastened to each other at the corners. When the duct work terminates at the damper or installation prohibits angles from turning out/away from the wall, the retaining angle shall be reversed (leg turned into the opening) providing the size of the opening is increased by an amount equal to twice the combined thickness of the angle and the height of the screw or bolt head to maintain expansion clearances. Angles can be placed in front of or behind the drywall attaching directly to the steel studs or masonry. U.E.'s Frame Retaining Angles (ANG) can be used in place of the angle mentioned above. See note 1B for information on clearances. See Fig. 8 for detailed drawings of installations.

c. No Angle Method: In this method No angles are used to secure the damper in the opening. This method is approved for use in UL approved concrete/masonry partitions and steel stud/gypsum walls. This method uses a minimum 3/4" (19mm) flange is on one end of the sleeve. The damper/sleeve assembly is placed in the opening so that the flange rest flush up to the partition, then the fasteners are placed through the sleeve into the partition (see Fig. 9). No Angle Method is approved for 1-1/2 hour dampers only, vertical and horizontal (flange on top side only) orientations, and the maximum size shall be 42" (1067mm) wide by 48" (1219mm) high up to the maximum multi-section UL approved damper size (see Underwriter's Laboratories Listings for maximum assembly sizes). The sleeve flange shall be a minimum of 3/4" (19mm) high by 20 gauge steel. If a flange/angle is added, it shall be a minimum of 1" x 1" (25mm x 25mm) by 18 gauge steel and fastened with #10 (M5) bolts or screws, 1/2" (13mm) welds, or 3/16" (5mm) rivets to the sleeve, at a maximum spacing of 6" (152mm) o.c., not more than 2" (51mm) from each end with a minimum of two fasteners per side. The sleeve is to be fastened to the fire partition with: **in concrete/masonry partitions** with #10 self-tapping concrete anchors or concrete screws on 6" (152mm) centers and must engage the fire partition a minimum of 1-1/2" (38mm); in steel stud/gypsum partitions secure the angles to the partition with #10 (M5) screws long enough to penetrate the J-Runners and E-Stud by a minimum of 3/8" (10mm). Use a minimum of two fasteners per side. The sleeve flange can be placed in front of or behind the drywall attaching directly to the steel studs or masonry. Be sure to not stretch the damper when securing it into the partition. Stretching the damper can cause it to bind up and prevent it from operating properly. UE's Frame Retaining Angles (ANG) can be used in place of the angle mentioned above. See note 1C for information on clearances. See Fig. 9 for detailed drawings of installations.



COMBINATION FIRE/SMOKE DAMPERS

(STATIC AND DYNAMIC)

Installation Instructions (continued)

5. Actuator Connections:

Electrical and/or pneumatic connections to damper actuators should be made in accordance with wiring and piping diagrams developed and in compliance with applicable codes, ordinances and regulations. Be sure to check actuator for proper voltage and current draw. Tampering with the actuator's installation or connecting the actuator to an improper voltage and current may void the warranty.

BREAKAWAY CONNECTIONS

Traditional Breakaway Style Transverse Joints

Transverse joints illustrated at right have always been approved as breakaway connections. SMACNA testing has also approved the following variations as breakaway connections.

• Standing 'S' joints can be applied with no. 10 sheetmetal screws (through joint and duct) subject to the following limitations: Maximum 2 screws in each side and in bottom joint.

• Transverse joints illustrated can be applied as top and bottom joints with Drive Slip - side joints in duct heights up to 20 inches. (508 mm)



Round and Oval Duct Breakaway Connections

Round or flat oval ducts connected to Type C, CR or CO damper collars may use no. 10 sheetmetal screws as follows:

- Ducts to 22" (558 mm) wide (or dia.) and smaller may use 3 screws.
- Ducts larger than 22" (558 mm) wide (or dia.) and up to 36" (914 mm) dia. may use 5 screws.
- Ducts larger than 36" (914 mm) wide (or dia.) may use 8 screws.

NOTE: All breakaway connections described may have duct sealant applied in accordance with SMACNA recommendations. Such as Design Polymeric, DP 1010.

Fig. 4

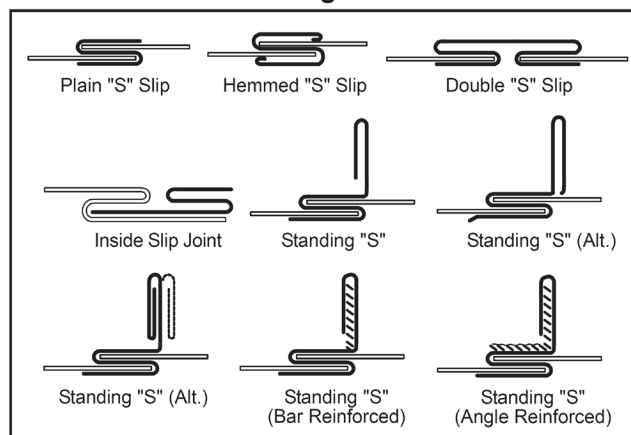

Manufactured Flanged System Breakway Connections

Flanged connection systems manufactured by Ductmate, Ward, and Nexus are approved as breakaway connections when installed as illustrated.

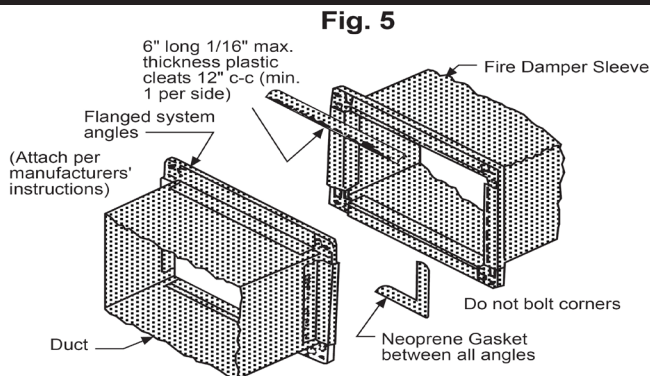

Proprietary Flange System Breakway Connections

TDC and TDF systems are approved as breakaway connections when installed as described in the TDC or TDF addendum to the SMACNA Duct Construction Standards except the corners may not be bolted. Standard 6" (152 mm) metal clip maybe used with spacing as shown in diagram.

Fig. 6

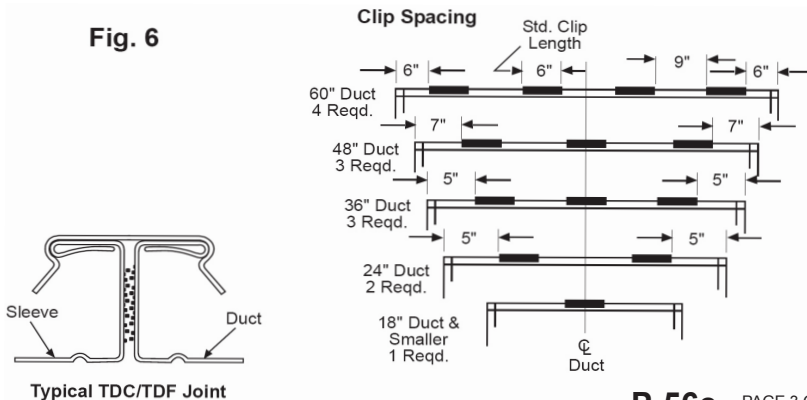



COMBINATION FIRE/SMOKE DAMPERS

(STATIC AND DYNAMIC)

Installation Instructions (continued)

Fig. 7 – Two Angle (Two Sided) Method

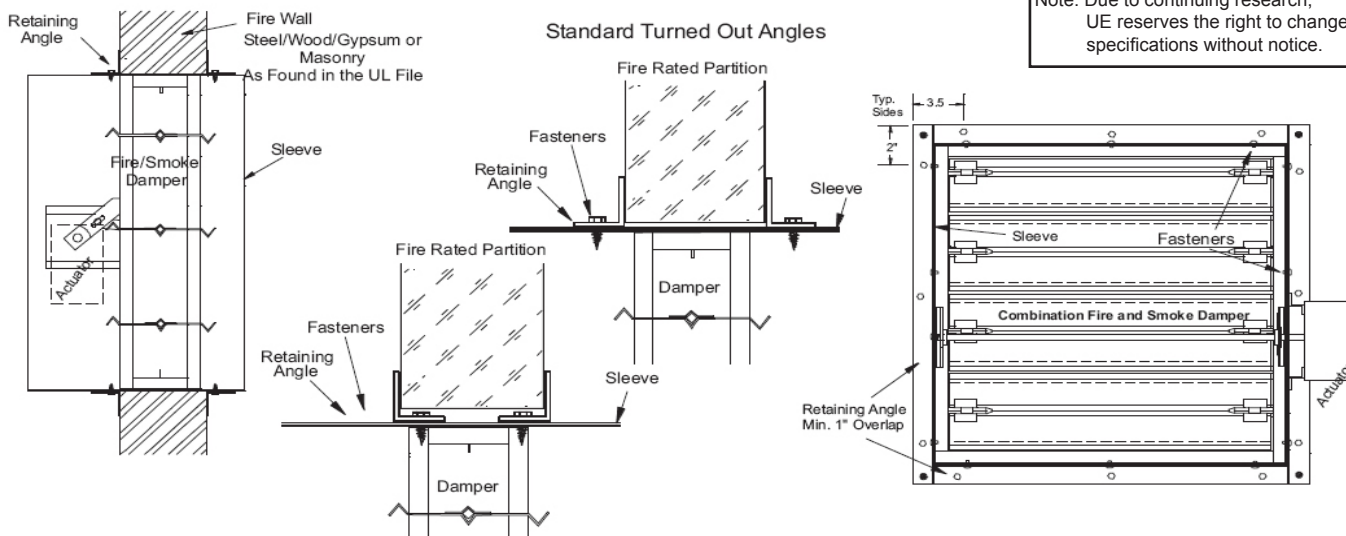

Fig. 8 -- One Angle (Single Sided) Method

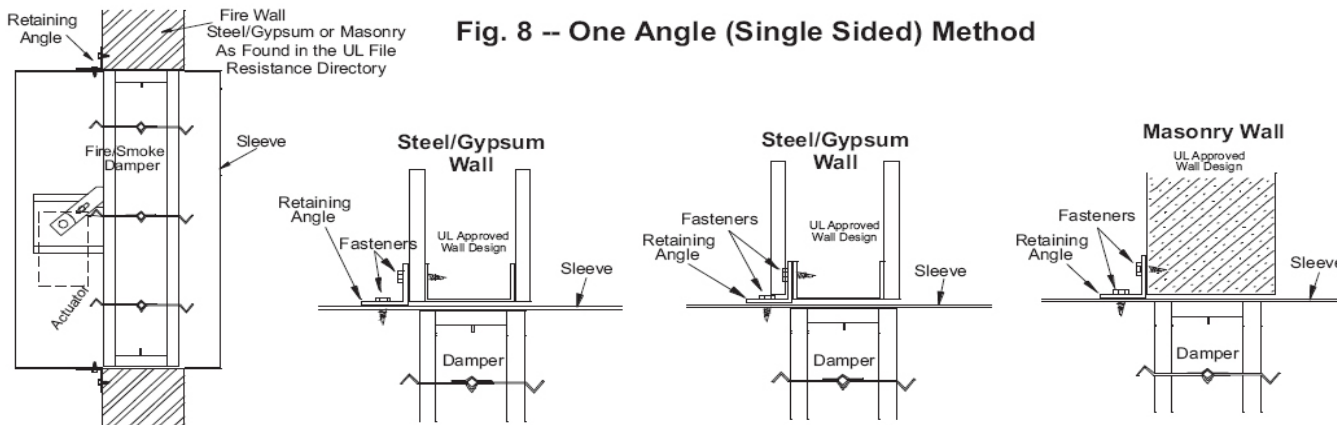
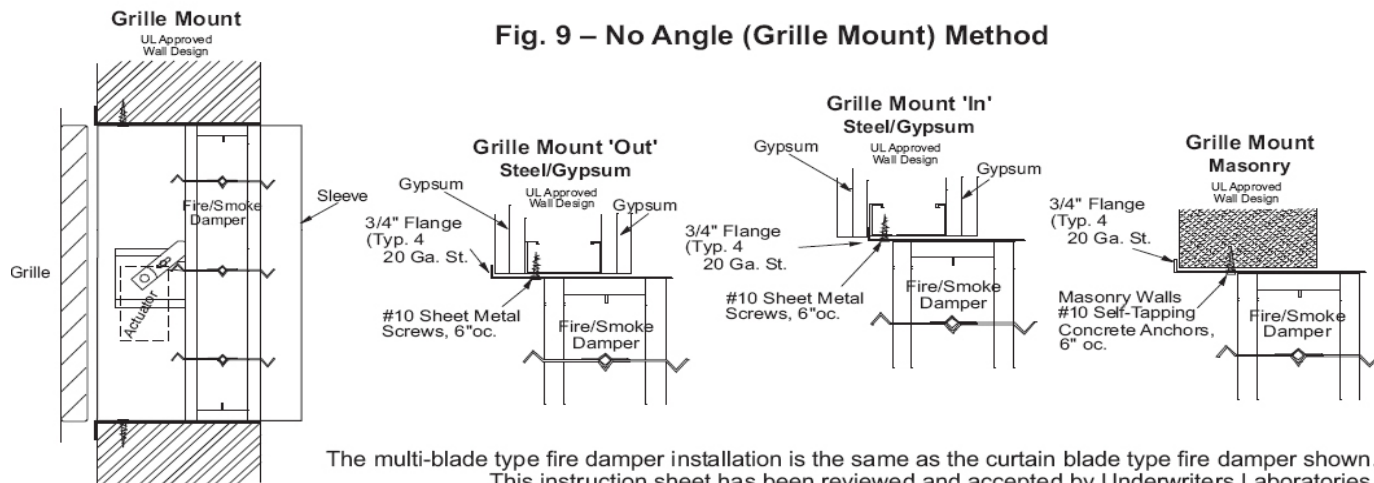

Fig. 9 – No Angle (Grille Mount) Method



The multi-blade type fire damper installation is the same as the curtain blade type fire damper shown. This instruction sheet has been reviewed and accepted by Underwriters Laboratories.

Manufacturer's Recommendations

All moving parts of the damper must be inspected and cycled at intervals not greater than every 12 months or in accordance with the latest edition of NFPA 90A, 92A, local codes and the actuator manufacturer. In addition, fuse links (if provided) shall be removed and inspected for corrosion. Dry lubricants are recommended.

When UL is referred to in this document, it represents UL/ULC.